



2012. The engine for construction equipment.

75 - 147 kW at 1500 - 2500 rpm



The new 1 litre class.

These are the characteristics of the 2012:

- Modern liquid-cooled 4- and 6-cylinder in-line engines.
- 1 litre displacement per cylinder. Compact design and high power-to-volume-ratio.
- Turbocharging and turbocharging with charge air cooling.
- High-pressure fuel injection up to 1600 bar.
- Electronic engine governor with diagnostic facilities and CAN-bus optional.
- 3 separate mounting options for gear-driven hydraulic pumps.
- Easy accessible service points on one engine side.
- Wedge ribbed belt drive with automatic belt tensioner optional.



Your benefits:

- ▶ Fast and powerful response to changing operating duties, dynamic power development.
- ▶ Low cost for noise insulation measures. High comfort in the driver's cab because of low noise level. Low noise emission, low environmental impact.
- ▶ High operating economy thanks to low fuel consumption, long oil change intervals and low maintenance requirement.
- ▶ Low exhaust emission for a clean environment. Meets exhaust regulation EU-RL 97/68 (Step 2) and US-EPA Nonroad (Tier 2).
- ▶ High reliability even under extreme working conditions.

► Engine description

Type of cooling:	Liquid cooling, thermostatically controlled at engine outlet. Charge-air-cooled engines with air-to-air charge air cooler.
Crankcase:	High grey cast iron crankcase, for monobloc construction.
Mass balance shafts:	4-cylinder optional with full mass balance by 2 shafts integrated into the crankcase.
Crankcase breather:	Closed-circuit crankcase breather.
Cylinder head:	Grey cast block-type cylinder head.
Valve arrangement/ timing:	Two valves per cylinder, actuated from gear driven camshaft via tappets, push rods and rocker arms.
Piston:	Three-ring aluminium piston.
Piston cooling:	Oil cooled with spray nozzles.
Connecting rod:	Forged steel rod.
Crankshaft:	Forged steel shaft with integral counterweights, 4-cylinder version with integral mass balancing shafts.
Camshaft:	Steel shaft.
Lubrication system:	Forced-feed circulation lubrication with gear pump.
Lube oil cooler:	Oil cooler integrated in coolant circuit.
Oil and fuel filter:	Paper-type microfilter as replaceable cartridge, optional exchangeable cup-shaped filter cartridges for environmentally compatible filter change from above.
Injection pump/ governor:	Single injection pumps integrated in crankcase. Mechanical centrifugal governor (standard); electronic engine governor (EMR) optional.
Fuel lift pump:	Mechanical gear pump integrated in v-belt drive.
Injection nozzle:	Six-hole nozzle, without leakoil.
Alternator:	Three-phase alternator 12 V or 24 V.
Starter motor:	12 V or 24 V.
old starting facilities:	Electric intake air preheater for spontaneous and environmentally compatible cold starting characteristics.
Heating system:	Optional connection for cab heating to engine cooling circuit.
Options:	Intake manifold, exhaust manifold, turbocharger positions, air compressor, hydraulic pump installation positions, SAE 2/3/4 flywheel housings, flywheels, 12 V or 24 V electrics, oil pans.

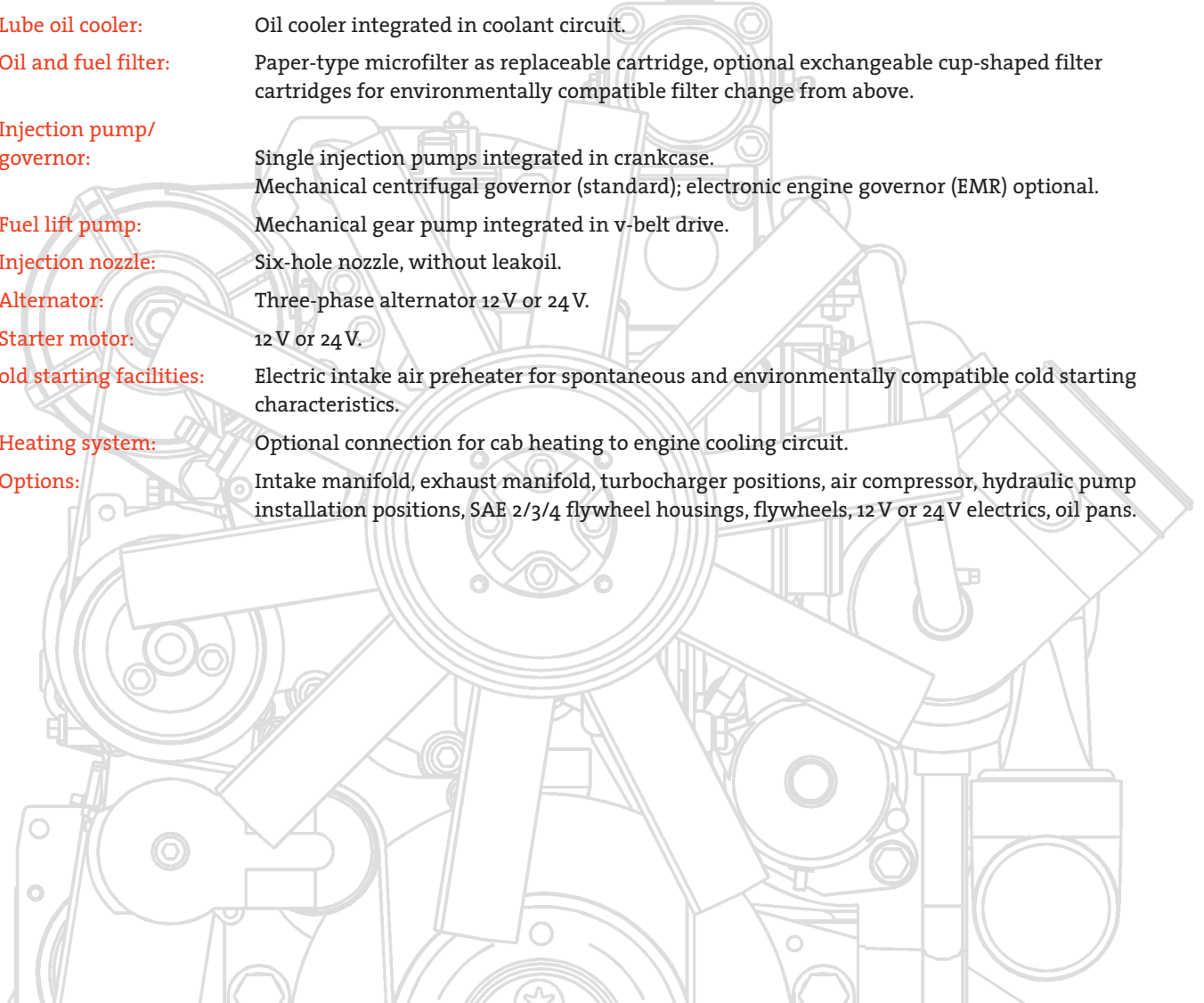

► Dimensions

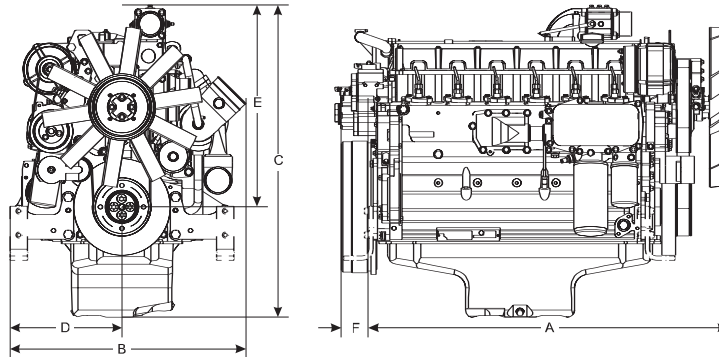

Engine with belt drive

		A	B	C	D	E	F
BF 4 M 2012	mm	742	643	741	300	506	105
BF 4 M 2012 C	mm	742	643	835	300	600	105
BF 6 M 2012 C	mm	998	628	920	300	600	105

Engine with wedge ribbed belt drive (Poly-V)

		A	B	C	D	E	F
BF 4 M 2012	mm	798	643	741	300	506	105
BF 4 M 2012 C	mm	798	643	835	300	600	105
BF 6 M 2012 C	mm	1015	628	920	300	600	105

► Technical data

Engine type		BF 4 M 2012	BF 4 M 2012 C	BF 6 M 2012 C
Number of cylinders		4	4	6
Bore/stroke	mm	101/126	101/126	101/126
Displacement	l	4.04	4.04	6.06
Compression ratio		19	19	19
Max. rated speed	rpm	2500	2500	2500
Mean piston speed	m/s	10.5	10.5	10.5

Power ratings for construction equipment engines ¹⁾

Power ratings for industrial engines ²⁾	kW	74.9	103	155
at speed	rpm	2500	2500	2500
Mean effective pressure	bar	8.9	12.2	12.3
Max. torque	Nm	390	493	743
at speed	rpm	1500	1500	1500
Minimum idle speed	rpm	800	800	800
Specific fuel consumption ³⁾	g/kWh	208	202	202
Weight to DIN 70020, part 7A ⁴⁾	kg	391	391	509

► Modell designation

BF 6 M 2012 C

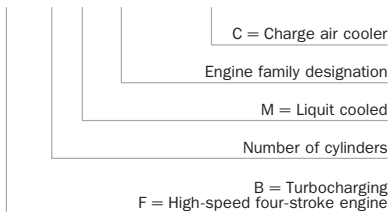

- 1) Power ratings without deduction of fan power requirement.
- 2) Fuel stop power to ISO 3046/1.
- 3) Specific fuel consumption based on diesel fuel with a specific gravity of 0.835 kg/dm³ at 15°C.
- 4) Without starter motor/alternator, radiator and liquids, however with flywheel and flywheel housing.

The values given in this data sheet are for information purposes only and not binding. The information given in the offer is decisive.

► Standard engines

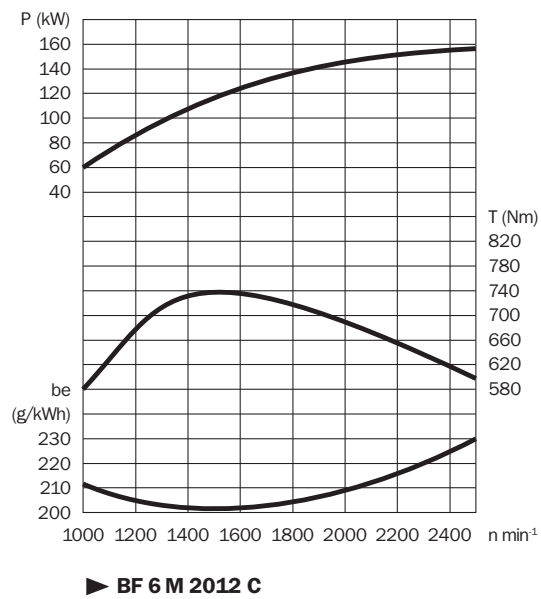
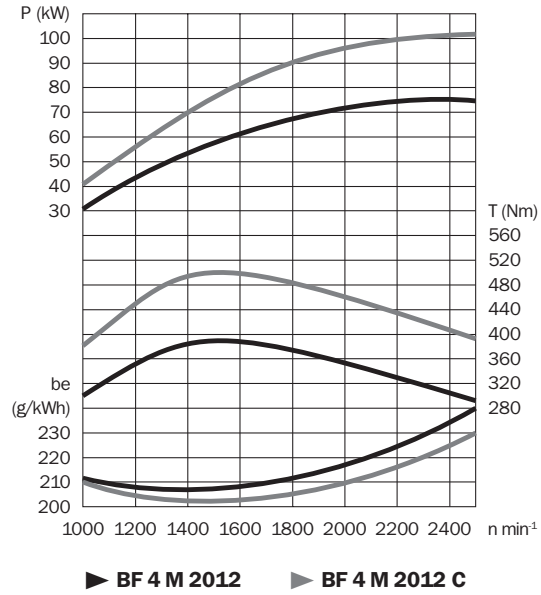



The engine company.

DEUTZ AG
DEUTZ MOTOR

Deutz-Mülheimer Str. 147-149

D-51063 Köln

Telephone: + 49 (0) 2 21-8 22-0

Fax: + 49 (0) 2 21-8 22-25 68

Internet: www.deutz.com

eMail: info@deutz.com